



# Smart Rigging®

The Intelligent Choice

# SR anti torsion

www.smartrigging.com • info@smartrigging.com

This anti torsion cable is specially engineered for the toughest conditions on board. We mount a special high tensile stainless steel torsion body to withstand the forces which occur while furling in rough conditions. To take these torsion forces the stay is over braided with layers of Aramide (Kevlar) When necessary we can put a special resin in the braid to get even more torsion stiffness in the cable. You can also use this cable in a lighter version for luff ropes. The body also has the Smart bumper to protect the lashing and the braid. We can supply several body designs with or without a lashing eye and we are already equipped for the newest generation super light weight furl units with a loop connection (Equiplite)

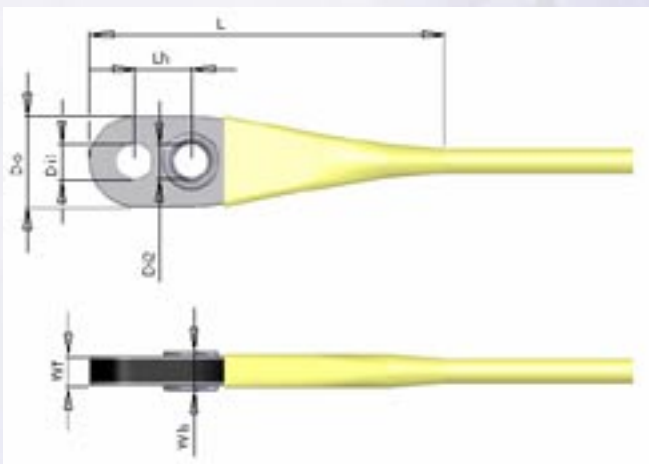

| SR Terminal | Break load [Tonne] | L [mm] | Do [mm] | Di1 [mm] | Di2 [mm] | Lh [mm] | W [mm] | Wls [mm] | Max Cable size |
|-------------|--------------------|--------|---------|----------|----------|---------|--------|----------|----------------|
| SR 10*      | 10                 | 152.0  | 40.0    | Custom   | 12.0     | 20.0    | 12.0   | 15.0     | SR10 BL        |
| SR 20       | 20                 | 188.0  | 48.0    | Custom   | 18.0     | 30.0    | 16.0   | 20.9     | SR20 BL        |
| SR 30*      | 30                 | 229.0  | 55.0    | Custom   | 24.0     | 38.0    | 18.0   | 23.0     | SR20 BL        |

\* Terminals under development, preliminary dimensions.

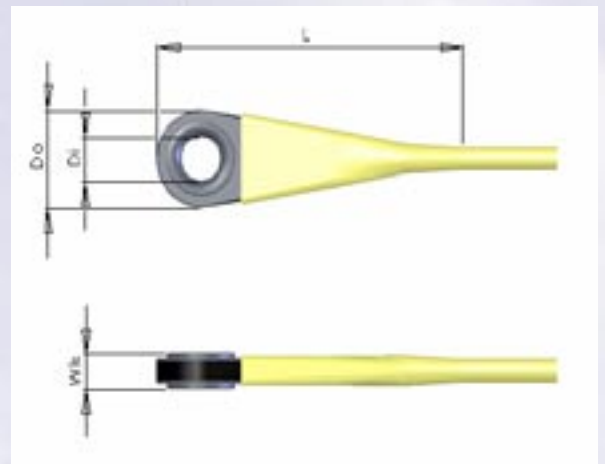

| SR Terminal | Break load [Tonne] | L [mm] | Do [mm] | Di [mm] | Wls [mm] | Max Cable size |
|-------------|--------------------|--------|---------|---------|----------|----------------|
| SR 12       | 12                 | 160.0  | 47.0    | 21.0    | 17.0     | SR12 BL        |
| SR 20*      | 20                 | 230.0  | 75.0    | 30.0    | 20.0     | SR20 BL        |

\* Terminals under development, preliminary dimensions.

More sizes available upon request